

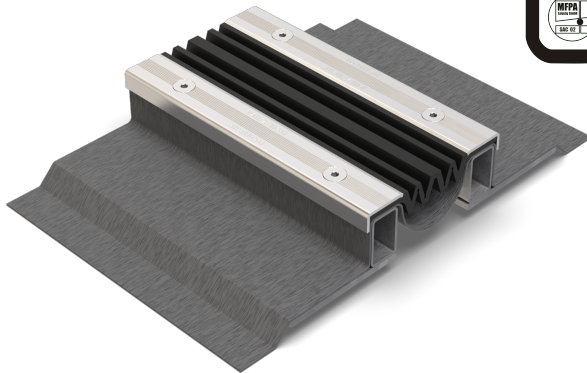

VA.8.135/.. F

- high load-bearing capacity
- anti-slip structured visible surface
- with general building authority test certificate



FEATURES

watertight, resistant to heavy loads, expansion insert can be replaced anytime, abrasion-, weather- and temperature-resistant (-40°C to +120°C), resistant to de-icing salt and waste water (alkalis, microbes, bacteria)

APPLICATIONS

parking decks, parking garages, underground garages, ramp crossings, pedestrian bridges

MATERIAL

substructure hot-dip galvanised steel and visible surface stainless steel V2A (V4A on request), EPDM expansion insert, Wolfin IB sealing membrane

COVERING TYPES

asphalt, screed, natural and stone slabs, bitumen welding membrane, liquid plastic, Flüssigkunststoff

TRAFFICABILITY

passenger cars, trucks

FORMED PARTS

corner piece, T-piece, cross piece, floor-wall connections, upstand, membrane upstand

NOTES

The sealing and expansion insert is flanged with screws M8 at intervals of 150 mm.

The sealing membrane projecting from the joint profile must be integrated into the sealing system to prevent water infiltration from the sides.

For profile height 38 mm minimum joint width 75 mm.

Bei Profilhöhe 23 mm geringe Belagsüberdeckung.

Installation by our own fitters recommended.

TECHNICAL DATA

Movement horizontal:	80 mm (-30/+50 mm)
Movement vertical:	30 mm (±15 mm)
Visible width:	135 mm
Maximal joint width:	100 mm
Load rating trucks:	600 kN (DIN 1072)
Supply length:	3 mtr
Color of expansion insert:	schwarz

DESIGNS

ARTICLE NO.	PROFILE HEIGHT (h)	RECESS (BxT)
VA.8.135/22 F	23 mm	1000 x 33 mm
VA.8.135/37 F	38 mm	1000 x 48 mm
VA.8.135/42 F	43 mm	1000 x 53 mm
VA.8.135/52 F	53 mm	1000 x 63 mm
VA.8.135/62 F	63 mm	1000 x 73 mm
VA.8.135/92 F	93 mm	1000 x 103 mm

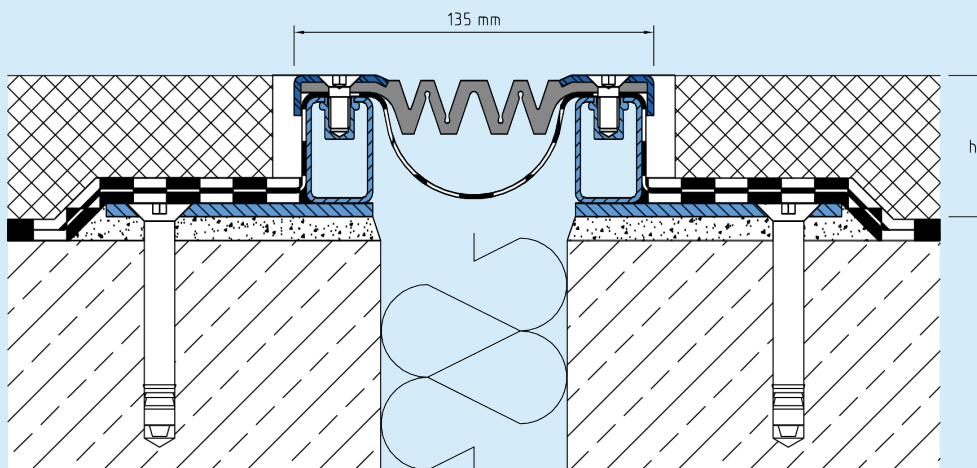

Subject to technical change without notice.

VA.8.135