

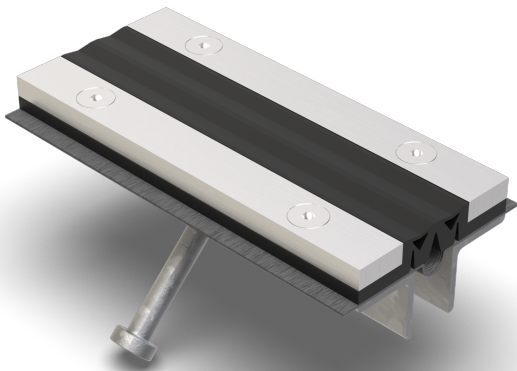

VA.8.110/0 G

- high load-bearing capacity
- hygiene-friendly and smooth expansion insert
- installation in site-mixed concrete



FEATURES

watertight, resistant to heavy loads, trafficable by fork-lift trucks, abrasion-, weather- and temperature-resistant (-40°C to +120°C), resistant to de-icing salt and waste water (alkalis, microbes, bacteria)

APPLICATIONS

parking decks, parking garages, underground garages, ramp crossings, pedestrian bridges, all industrial applications, areas with increased hygiene standards (e.g. kitchens, hospitals etc.)

MATERIAL

substructure hot-dip galvanised steel and visible surface stainless steel V2A (V4A on request), EPDM expansion insert, Wolfin IB sealing membrane

COVERING TYPES

coating, concrete, industrial coverings

TRAFFICABILITY

passenger cars, trucks, fork-lifts

FORMED PARTS

upstand, end piece, corner piece, T-piece, cross piece, floor-wall connections

NOTES

The sealing and expansion insert is flanged with screws M10 at intervals of 150 mm.

Grouting profile VP40/20 is already fitted at the factory.

The sealing membrane projecting from the joint profile must be integrated into the sealing system to prevent water infiltration from the sides.

Installation by our own fitters recommended.

TECHNICAL DATA

Movement horizontal:	20 mm (-10/+10 mm)
Movement vertical:	10 mm (-5/+5 mm)
Visible width:	108 mm
Maximal joint width:	28 mm
Load rating:	wheel load 5000 kg up to Ø 150 mm, B = 100 mm
Load rating trucks:	600 kN (DIN 1072)
Load rating forklifts:	150 kN (DIN 1055-3)
Supply length:	3 mtr
Color of expansion insert:	schwarz

DESIGNS

ARTICLE NO.	PROFILE HEIGHT (h)
VA.8.110/0 G	62 mm

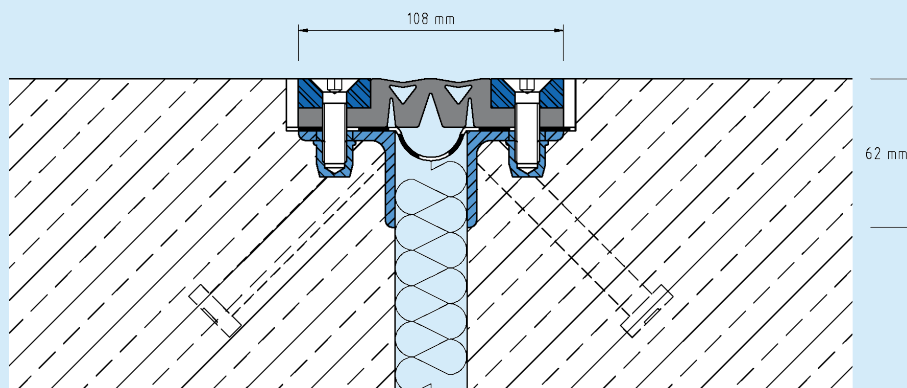

Subject to technical change without notice.

VA.8.110