

# ALR.8.150/..

- high load-bearing capacity
- with coating-flange

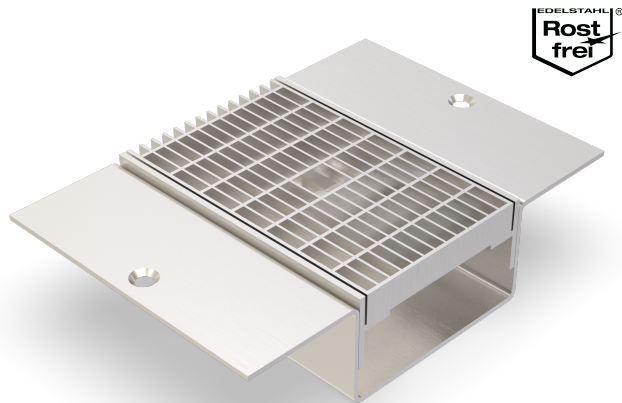

## FEATURES

permanently tight, corrosion-resistant, high flexibility (variable lengths, heights and widths), grating with mesh size 30x10 mm (30x30 mm on request), grid lock inclusive

## APPLICATIONS

parking decks, parking garages, underground garages, all industrial applications, shopping centres, railway stations, airports, exhibition halls

## MATERIAL

hot-dip galvanised steel, stainless steel V2A (V4A on request)

## COVERING TYPES

coating

## TRAFFICABILITY

passenger cars (trucks on request)

## FORMED PARTS

corner piece, T-piece, cross piece, channel end piece (flange all around or upstand), channel drain

## NOTES

The individual channel elements are tightly welded together during installation on site.

For stainless steel, the general cleaning and care instructions must be observed (see also download area).

Installation by our own fitters recommended.

## TECHNICAL DATA

Material thickness channel body:	4 mm
Material thickness mounting bracket:	5 mm
Supply length:	3 mtr
Steel grating width:	150 mm

## DESIGNS

ARTICLE NO.	CHANNEL HEIGHT (h)	RECESS (BxT)
ALR.8.150/50	50 mm	210 x 65 mm
ALR.8.150/60	60 mm	210 x 75 mm
ALR.8.150/90	90 mm	210 x 105 mm
ALR.8.150/120	120 mm	210 x 135 mm
ALR.8.150/150	150 mm	210 x 165 mm

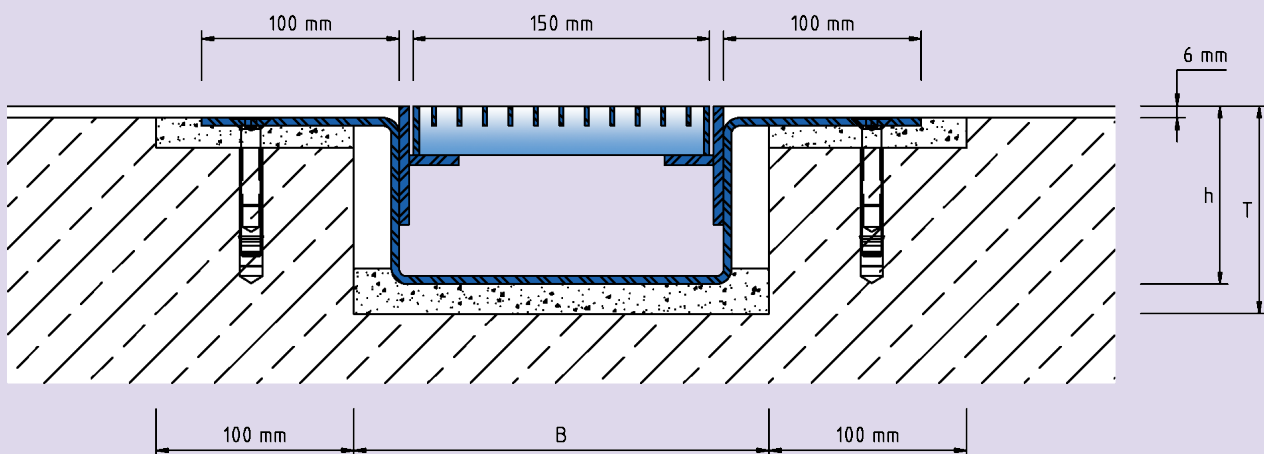

ALR.8.150

Subject to technical change without notice.