

ALR.3.200/..

- high load-bearing capacity
- with loose/fixed flange

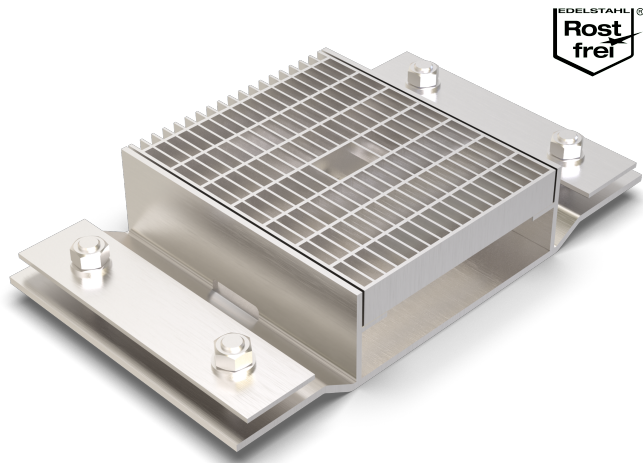

FEATURES

resistant to heavy loads, permanently tight, corrosion-resistant, high flexibility (variable lengths, heights and widths), grating with mesh size 30x10 mm (30x30 mm on request), grid lock inclusive

APPLICATIONS

parking decks, parking garages, underground garages, all industrial applications, shopping centres, railway stations, airports, exhibition halls

MATERIAL

hot-dip galvanised steel, stainless steel V2A (V4A on request)

COVERING TYPES

asphalt, screed

TRAFFICABILITY

passenger cars (trucks on request)

FORMED PARTS

corner piece, T-piece, cross piece, channel end piece (flange all around or upstand), channel drain

NOTES

The individual channel elements are tightly welded together during installation on site.
 Drainage slots are possible (on request).
 For stainless steel, the general cleaning and care instructions must be observed (see also download area).
 Installation by our own fitters recommended.

TECHNICAL DATA

Material thickness fixed flange: 6 mm
 Material thickness vertical base: 5 mm
 Supply length: 3 mtr
 Steel grating width: 200 mm

DESIGNS

ARTICLE NO.	CHANNEL HEIGHT (h)	RECESS (BxT)
ALR.3.200/81	81 mm	480 x 40 mm
ALR.3.200/101	101 mm	480 x 40 mm

Special heights on request.

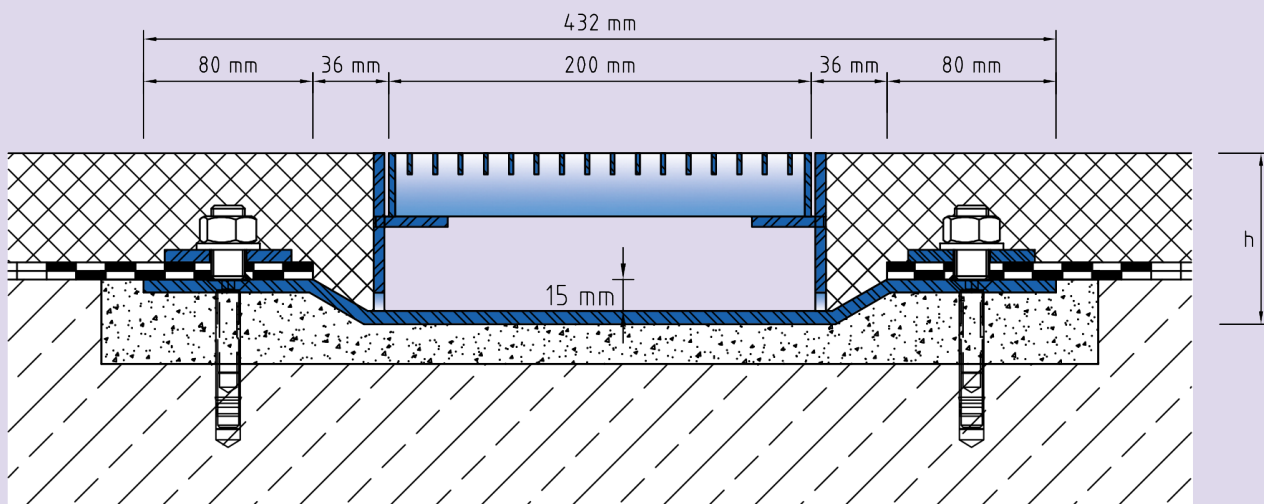

ALR.3.200

Subject to technical change without notice.