



AL.2.31/.. ÜG

- replaceable expansion insert
- hygiene-friendly and smooth expansion insert
- non-PVC
- projecting expansion insert

FEATURES

expansion insert can be replaced anytime, abrasion-, weather- and temperature-resistant (-40°C to +120°C), perforated bearing legs guarantee the best connection to the substrate/covering, the joint profile is laid with a flush insert during the screed work and can therefore be used as a stripping edge, the overlap inlay supplied separately on rollers is replaced with the existing inlay during the covering work

APPLICATIONS

residential, office and administration buildings, hospitals and clean rooms

MATERIAL

aluminium, EPDM expansion insert

COVERING TYPES

screed with upper layer from linoleum, rubber or carpet

FORMED PARTS

corner piece, T-piece, cross piece

NOTES

Projection of the expansion insert: 3 mm

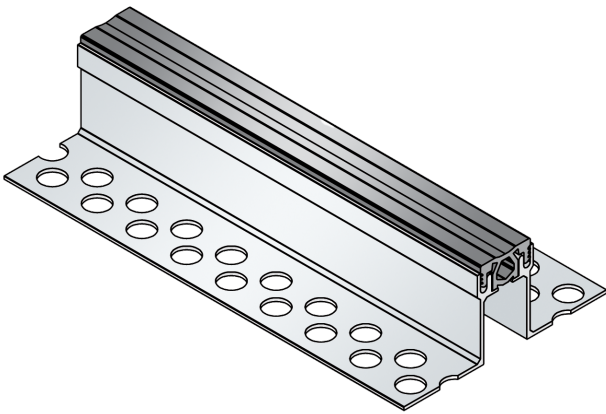

TECHNICAL DATA

Movement horizontal:	6 mm (±3 mm)
Movement vertical:	6 mm (±3 mm)
Visible width:	31 mm
Maximal joint width:	30 mm
Load rating:	wheel load 500 kg up to Ø 150 mm, B = 100 mm
Supply length:	3 mtr
Color of expansion insert:	grau

DESIGNS

ARTICLE NO.	PROFILE HEIGHT (h)
AL.2.31/23 ÜG	23 mm
AL.2.31/38 ÜG	38 mm
AL.2.31/53 ÜG	53 mm

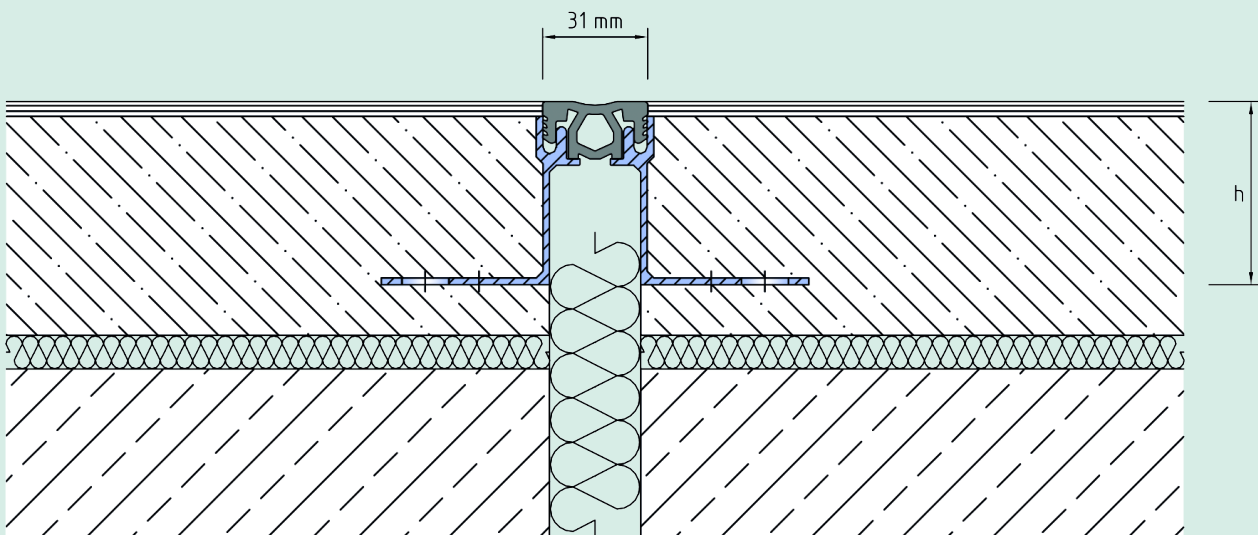

AL.2.31

Subject to technical change without notice.